



Kreatif Fikirler
Creative Ideas



Profesyonel Mühendislik
Professional Engineering



Çözüm Odaklılık
Solution Oriented

**KRİYOJENİK
DEPOLAMA &
TAŞIMA TANKLARI**

**CRYOGENIC STORAGE &
TRANSPORT TANKS**

(LIN-LAR-LOX-LNG)

**KARBONDİOKSİT
TANKLARI**

**CARBON DIOXIDE
TANKS**

**LPG TANKLARI
LPG TANKS**

**HAVA & GAZ TANKLARI
AIR & GAS TANKS**

**BASINÇ ODALARI
PRESSURE CHAMBERS**

**EVAPORATÖRLER
EVAPORATORS**

ZEEMAN
ENGINEERING

**KRİYOJENİK TANK UZMANI
CRYOGENIC TANK SPECIALIST**

www.zeemanmuhendislik.com





Zeeman is also specialized in project design, manufacturing and assembly. Product quality, customer demands and customer satisfaction will be the continuity of our business success. The highest level of customer satisfaction will be achieved and the highest level of quality, efficiency and flexibility will be achieved by aiming to control every stage of the business process.

In this regard, the outlines of our quality policy are as follows;

- Ensuring the highest level of customer satisfaction,
- Continuously improving product quality with R&D studies and reducing costs with the participation of all employees,
- Ensuring that the requirements related to the work we have done to our suppliers are constantly communicated in a clear and understandable way,
- Continuing quality improvement activities in a systematic and planned manner with the participation of all people, giving priority to meeting the requirements of our internal and external customers,
- Organizing continuous training programs for all our employees,
- Protecting the environment we work with and using our limited resources in a way that creates at least waste,
- Ensuring that every work we do is done correctly the first time and again and ensuring continuity in quality improvement efforts.



OUR MISSION

ZEEMAN has undertaken the mission of being among the best companies in the world and domestic market in the sector with its experienced and strong staff in the field of cryogenic transport tanks, storage tanks system installation and system equipment design and production, installation and technical service for industrial and medical (medical) gases. The company has an up-to-date machine park, high-capacity production facility, all renewed and sought-after quality certificates and important references in the sector. It makes its difference among many companies in the sector with its ever-increasing production capacity and product range.

OUR VISION

- 1- To be the best supplier and solution partner of the institutions and organizations we serve.
- 2- To be one of the first implementers of new technologies and solutions in our industry.
- 3- To be an exemplary and expert production center that has completed its integration in its sector and modernization applications.
- 4- To increase the value of our company in line with the principle of continuous improvement and with healthy growth.
- 5- To increase the satisfaction of our customers and employees.
- 6- To produce stable and continuous services to the institutions and organizations of our field of activity.
- 7- To carry out manufacturing and design activities covering efficient production and innovative technology with our R&D processes.
- 8- To lead the industry and industrial sector by supporting the realization of projects registered by the Turkish Patent Institute or similar organizations.



ZEEMAN
ENGINEERING

CRYOGENICS

ZEEMAN Engineering deals with the design, manufacture, installation, maintenance and optimization of the performance of systems used in cryogenic applications in a safe, efficient and durable manner. In this process, the entire process is supported by professional engineering methods, taking into account factors such as material selection, insulation technologies, geometry of the tank and compressive strength.

* Temperatures between $[-150^{\circ}\text{C}]$ and absolute zero $[-273^{\circ}\text{C}]$ are defined as Cryogenic Temperature values.

Cryogenic systems allow liquefied gases to be stored and transported under low temperature and high pressure.

For this reason, with the wrong choice of material, materials can become fragile, loss of efficiency can occur and lead to potential hazards.

ZEEMAN Engineering selects and records these materials in accordance with international standards so that they remain stable at low temperature and can be used in optimum conditions.





$$\frac{p}{10} \cdot \left(\frac{A_p}{A_s} + \frac{1}{2} \right) \leq \frac{K}{S}$$

$$I_{w,y} = \sum \frac{a \times I_w^3}{12} \quad \text{Formula 26}$$

$$\frac{17}{10} \cdot \left(\frac{91769,2}{1746} + \frac{1}{2} \right) \leq \frac{250}{1,5}$$

$90,20 \leq 166,67 \text{ N/mm}^2$ no dabin

$$\left(\frac{K_0}{S} - \frac{p}{20} \right) A_{\sigma 0} + \left(\frac{K_1}{S} - \frac{p}{20} \right) A_{\sigma 1} + \left(\frac{K_2}{S} - \frac{p}{20} \right) A_{\sigma 2} \geq \frac{p}{10} A_p \quad \text{Formula 27}$$

$$\left(\frac{250}{1,5} - \frac{17}{20} \right) \cdot 1560 + \left(\frac{230}{1,5} - \frac{17}{20} \right) \cdot 93 + \left(\frac{230}{1,5} - \frac{17}{20} \right) \cdot 93 \geq \frac{17}{10} \cdot 91769,2$$

$287035,9 \text{ N} \geq 156007,64 \text{ N}$ The desing condition is ok.

$$\left(\frac{250}{1,05} - \frac{24,31}{20} \right) \cdot 1560 + \left(\frac{230}{1,05} - \frac{24,31}{20} \right) \cdot 93 + \left(\frac{230}{1,05} - \frac{24,31}{20} \right) \cdot 93 \geq \frac{24,31}{10} \cdot 91769,2$$

$410049,17 \text{ N} \geq 223090,92 \text{ N}$ The test condition is ok.

$$\tau_{\perp} = \frac{N}{A_w} + \frac{M_y}{I_{w,y}} \times \frac{I_w}{2} \quad \sigma_{\perp} = \frac{N}{A_w} + \frac{M_y}{I_{w,y}} \times z$$

$$\tau_{\parallel} = \frac{V_z \cdot S_w}{I_w \cdot \Sigma a} \quad \sigma_{v,w} = \sqrt{\sigma_{\perp}^2 + \tau_{\perp}^2 + \tau_{\parallel}^2}$$

$$p_p = \frac{20 \cdot K \cdot s - c}{S_p \cdot D_a} \cdot \frac{u}{1 + \frac{1,5u(1 - 0,2(D_a/l_b))D_a}{100(s - c)}} \quad \text{Formula (6)}$$

Zeeman is based on the analysis of applications such as heat transfer, thermodynamics, fluid mechanics and statics, based on the basic principles of mechanical, chemical, welding and physical engineering and in accordance with engineering modeling principles, by correctly connecting with advanced engineering ideas.

This situation positions the company not only as a company that manufactures, but also as a company that provides a strong engineering service. It is designed analytically in accordance with **PED** and **TPED** directives and in accordance with **EN 13458-2**, **EN 13530-2**, **EN 13445**, **A5ME SecVIII Div1**, **gas DT AD 2000**, **EN14025**, **EN12252**, **EN 12495** standards and submitted to the approval of the audit body after calculation and projecting.

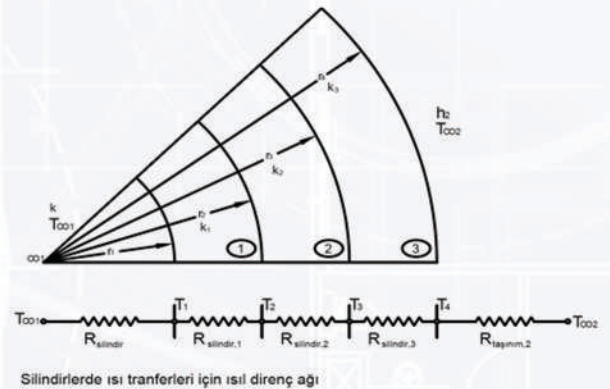
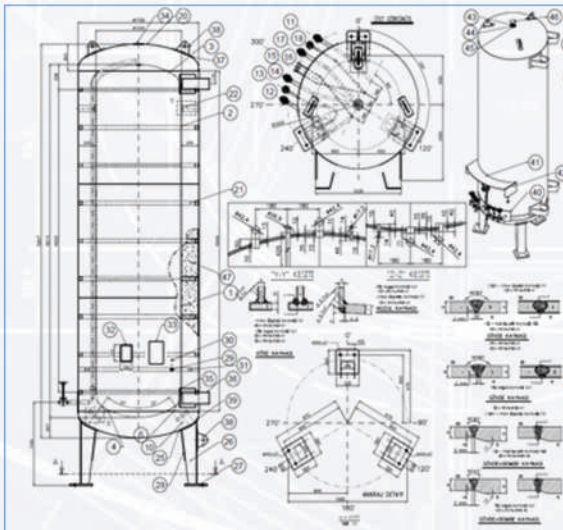

ZEEMAN performs its welded productions according to **EN ISO 3834** standard. ZEEMAN Welding Operators are certified according to **EN 150 14732** standard and Welders are **EN ISO 9606 - 1** and **EN ISO 9606 - 2** certified.



It makes production by determining the material properties and dimensions to be used in accordance with the design of the product during the preparation process

Preparing the calculation report and technical drawings and submitting them to independent audit institutions. Procurement of certified materials following approval of reports.

Completion of WPSs before welding (EN15609-X) taking samples from past productions suitable for production and by revealing knowledge about welding technique



Zeeman uses the SAW (Submerged Arc Welding) welding method, referred to as the '121 SAW' welding method, along with other welding methods. The saw welding method is an automatic arc welding method used to join metal parts.

This method is used to obtain high efficiency, quality and high strength resources. The automatic operation makes it possible to weld along large and long welding lines in a single pass, which increases productivity. Zeeman has a PQR test up to 60 mm in stainless steel.

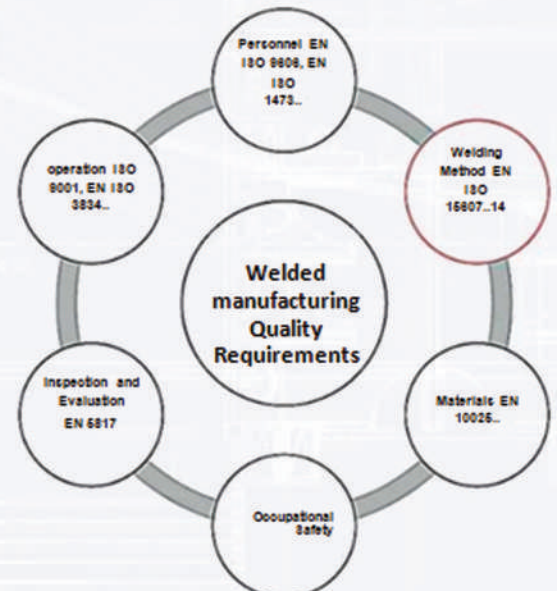

CRYOGENIC STORAGE TANKS (LIN-LAR-LOX)

It becomes possible to achieve optimum design and to store the product in the tanks for longer periods of time without increasing the pressure with Zeeman's engineering design.

STORAGE TANKS LOX/LAR/LIN/LNG DESIGN FEATURES			
Design Standard	The tanks we manufacture are designed and manufactured in accordance with ASME Sec VII Div.1, AD-MERKBLATT, TS EN 13458, ANNEX C, ASME standards in line with the request of our customers. Following the design processes, calculation reports and manufacturing projects are submitted to 3rd party institutions and manufacturing starts after approval.		
Products to be stored	LIQUEFIED OXYGEN (LOX) / ARGON (S) / NITROGEN (S) / NATURAL GAS (LNG)		
Tank Types	Vertical / Horizontal + Thermosiphon	Volume range	1-250 m ³
Documentation Type	"CE" certification (B+F)		
Isolation Type	Perlite + Vacuum (Insulation is provided by perlite + two-wall vacuuming method.) The inner surface of the outer tank is under absolute vacuum.		
	INNER TANK		EXTERNAL TANK
Operating Pressure range	3-37	bat	-1 <u>bar</u>
Design Temperature	-196, +50	• C	-50, +50 ° C
Examination Method	Butt welds 100% RT, Corner Welds 100% PT 100% crack control in nozzle welds	Nitrogen/Helium Control Leakage test between inner tank and outer tank at 4 bar.	
Material Used	EN 10028-7:2008 Cryoionic based stainless material (PED)		EN 10025-2:2004 S355J+
Welding Methods	TIG (GTAW) + SAW		SAW (121)

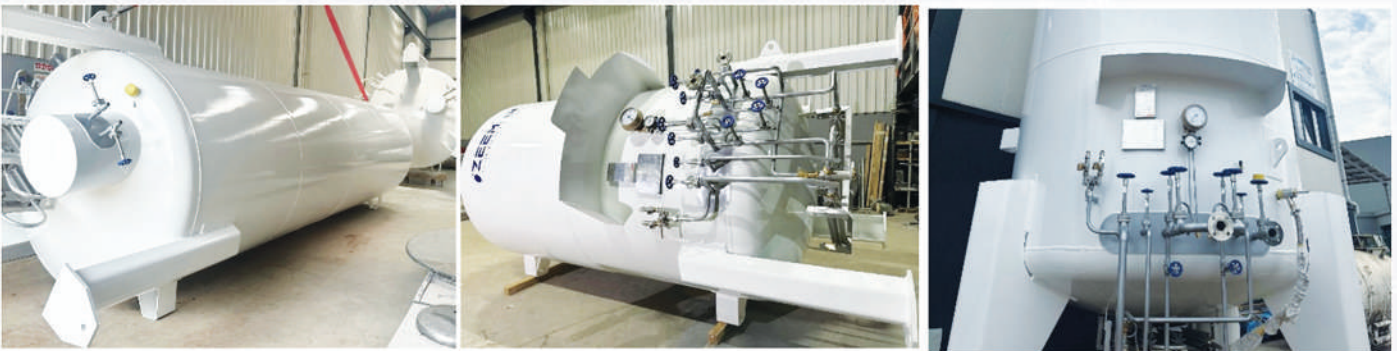

CRYOGENIC STORAGE TANKS (LIN-LAR-LOX)

Manufacturing of inner tank and outer envelope: Tank welds are carefully made by certified welders, cleaned, NDT (EN 24063 Standard) following the completion of the main body joints, and hydrostatic testing under the supervision of the approved organization after the piping is manufactured.

Following the assembly process of the finished tanks (main body and envelope), the tightness test between the two walls is carried out.



If there is a customer request, the tanks are assembled by expert teams. Technical information on the operation of the tank is provided to the tank users in the form of training and also training information and usage directives are provided to the users in a booklet.

Following the isolation and vacuumization of the tank, the tanks, which are completed by painting the tank, are washed with liquid nitrogen to make them independent from oxygen on the one hand and subjected to pre-cooling on the other hand.



Valve group siphon design with outlet from lower grenade



Each tank is labeled with quality tags and labels indicating all the characteristics of the tank. Tanks are delivered with quality file and CE certificate.

CRYOGENIC TRANSPORT TANKS (LIN-LAR-LOX)

ZEEMAN
ENGINEERING

TRANSPORT (SEMI-TRAILER) TANKS LOX/LAR/LIN/LNG DESIGN FEATURES						
Design Standard	The tanks we manufacture are designed and manufactured in accordance with our customers' requests and EN 13530-2 standards. Following the design processes, calculation reports and manufacturing projects are submitted to 3rd party institutions and manufacturing starts after approval.					
Products to be stored	LIQUEFIED OXYGEN (LOX) / ARGON (S) / NITROGEN (S) / NATURAL GAS (LNG)					
Tank Types	LOX/LAR/LIN	Horizontal	With Transfer Pump / Pressurization Evaporator	Volume range	20-33	3 m
	LNG	Horizontal	With Transfer Pump / Pressurization Evaporator	Volume range	46-54	3 m
Documentation Type	"CE" certification (B+F)					
Isolation Type	Multilayer super <u>insulation</u> + Vacuum (Insulation + between two walls is provided by vacuuming method.) The inner surface of the outer tank is under absolute vacuum.					
	INNER TANK			EXTERNAL TANK		
Operating Pressure range	3-16			-1 bar		
Design Temperature	-196, +50 °C			-50, +50 °C		
Examination Method	Butt welds 100% RT, Corner Welds 100% PT 100% crack control in nozzle welds			Nitrogen/Helium Control Leakage test between inner tank and outer tank at 4 bar.		
Material Used	EN 10028-7:2008 Cryogenic based stainless material (PED)			EN 10025-2:2004 S355J+		
Welding Methods	TIG (GTAW) + saw			SAW(121)		

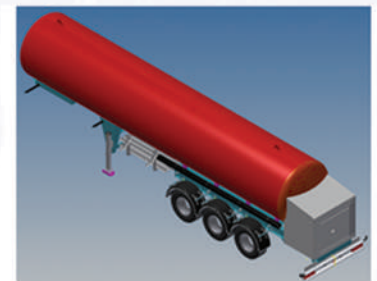
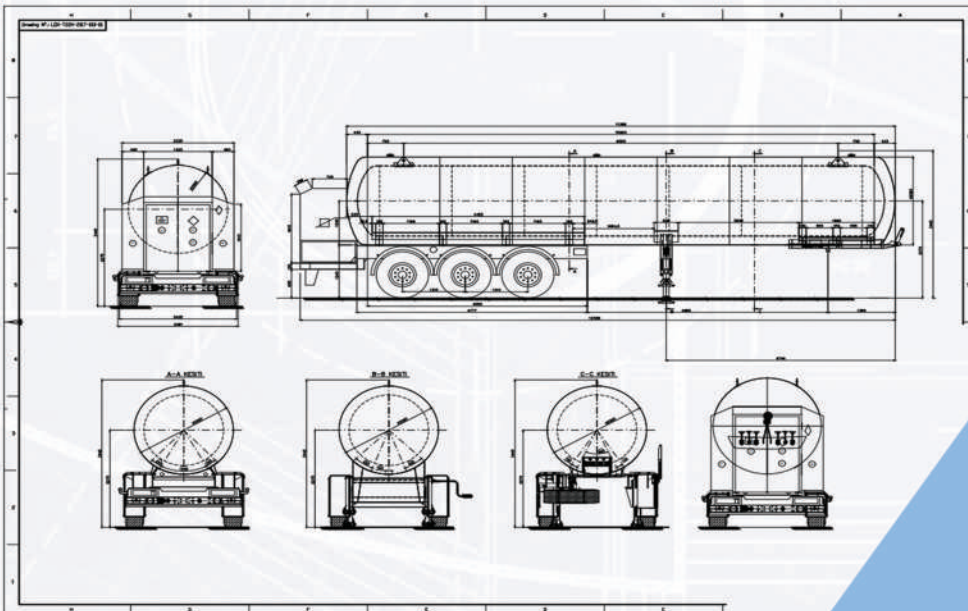

CRYOGENIC TRANSPORT TANKS (LIN-LAR-LOX)

ZEEMAN
ENGINEERING

Cryogenic semi-trailer systems are designed to transport cryogenic gases such as liquefied LIN, LOX, LAR, and LNG at maximum weight considering their density.



Super multi-layer insulation and cryogenic semi-trailer design, which takes into account the gas that the customer wants to use, makes it possible to achieve optimum design as well as to store the gas in the tankers for longer periods of time without increasing the pressure.



Tanker filling can be done by differential pressure or by a centrifugal pump. The design and pump layout for the cabinet can be designed according to the technical specifications that our customers want and need.

Simple piping placement in cryogenic semi-trailers minimizes the risk of possible leakage.





These tankers are produced in volumes of 5,000 to 15,700 liters at pressures between 3 and 18 bar. The tare weights of cryogenic truck-mounted tanks have been reduced through very innovative weight-saving practices, while ensuring that performance and durability are not affected, and that the vehicles have excellent thermal performance suitable for long standby.

Like our other mobile tanks, our truck mounted cryogenic tanks and their accessories can be designed according to customer requirements. Small tanks can be mounted on the vehicle chassis, making them suitable for many applications. Gas filling can be done with the help of pressure difference or centrifugal pump.



CRYOGENIC ISO TANK CONTAINER

The carbon steel frame has 20" and 40" standard ISO Container specifications. Lifting is done only from standard container corners. The container is safely transported by locking on rail and road vehicles in accordance with the ISO 668 standard for cargo containers. On the long side of the tank there is an operation cabinet with the necessary valves and accessories. The installation of valves and accessories is designed to create easy and safe working conditions.



CARBON DIOXIDE STORAGE TANKS

CO2 STORAGE TANKS DESIGN FEATURES					
Design Standard	The tanks we manufacture are designed and manufactured in accordance with ASME Sec VII Div 1, AD-MERKBLATT, EN 13445, TS EN 13458-2 standards in line with the request of customers. Following the design processes, calculation reports and manufacturing projects are submitted to 3rd party institutions and manufacturing starts after approval.				
Product to be Stored	CO2 (UN 1951)				
Tank Type	Cryogenic	Vertical	Sump	1-400	M ³
		Horizontal		1-400	
	PUR Insulated	Horizontal	1-400		
Documentation Type	"CE" certification(B+F)		Isolation Type	Perlite + Vacuum PUR Insulated	
	INNER TANK			EXTERNAL TANK	
				Cryogenic	PUR Insulated
Maximum Operating Design	22	bar	-1	-	bar
Design	-40, +50	°C	-20, +50	-20, +50	°C
Examination Method	Butt welds 100% RT, Corner Welds 100% PT		Nitrogen Control	-	
Material Used	EN 10028-7:2008 P355GH/NH		EN 10025-2:2004 S355J+	ALUMINIUM JACKET	
Welding Methods	TIG (GTAW) +saw		SAW	-	

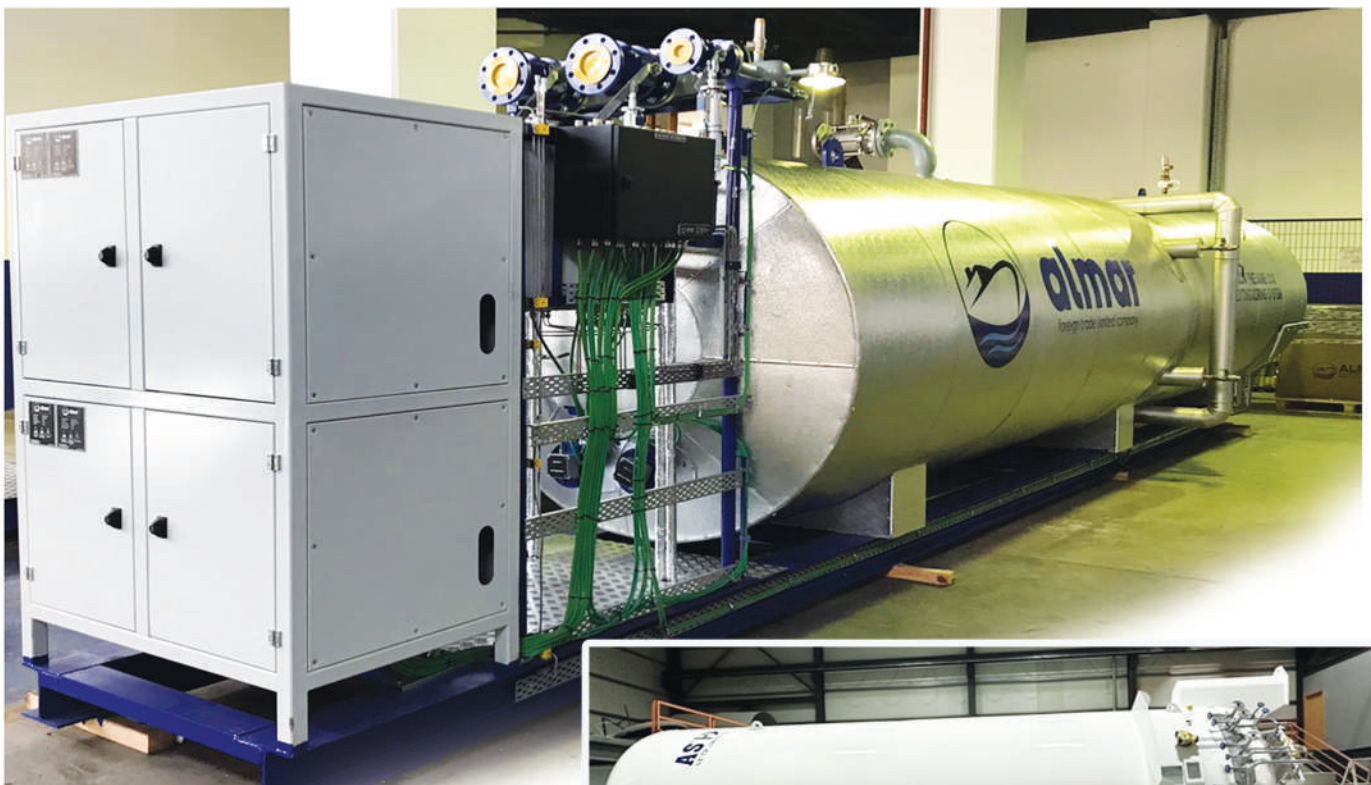

VACUUM-INSULATED HIGH-CAPACITY CARBON DIOXIDE TANKS

Cryogenic high-capacity carbon dioxide storage tanks enable safe, flexible and low operating costs storage of liquid carbondioxide thanks to perlite + vacuum insulation, which provides good thermal insulation.

Zeeman high-capacity carbon dioxide tanks are shipped to the end user complete with piping system, three-way double safety valve, level indicator and automatic pressurization system that allows easy and fast installation. These tanks can also be manufactured according to A5ME standards depending on demand.

Atmospheric vaporizers, pipelines and other cryogenic evaporators are supplied with the tank to ensure a complete installation of high-capacity cryogenic carbon dioxide tanks.

Although there is a standard design used in these tanks, they can be redesigned according to the desired technical specifications for special applications and needs.

High-capacity cryogenic carbon dioxide tanks are designed in accordance with Directive 97/23/EC and manufactured according to AD 2000M and EN 13458 standards.

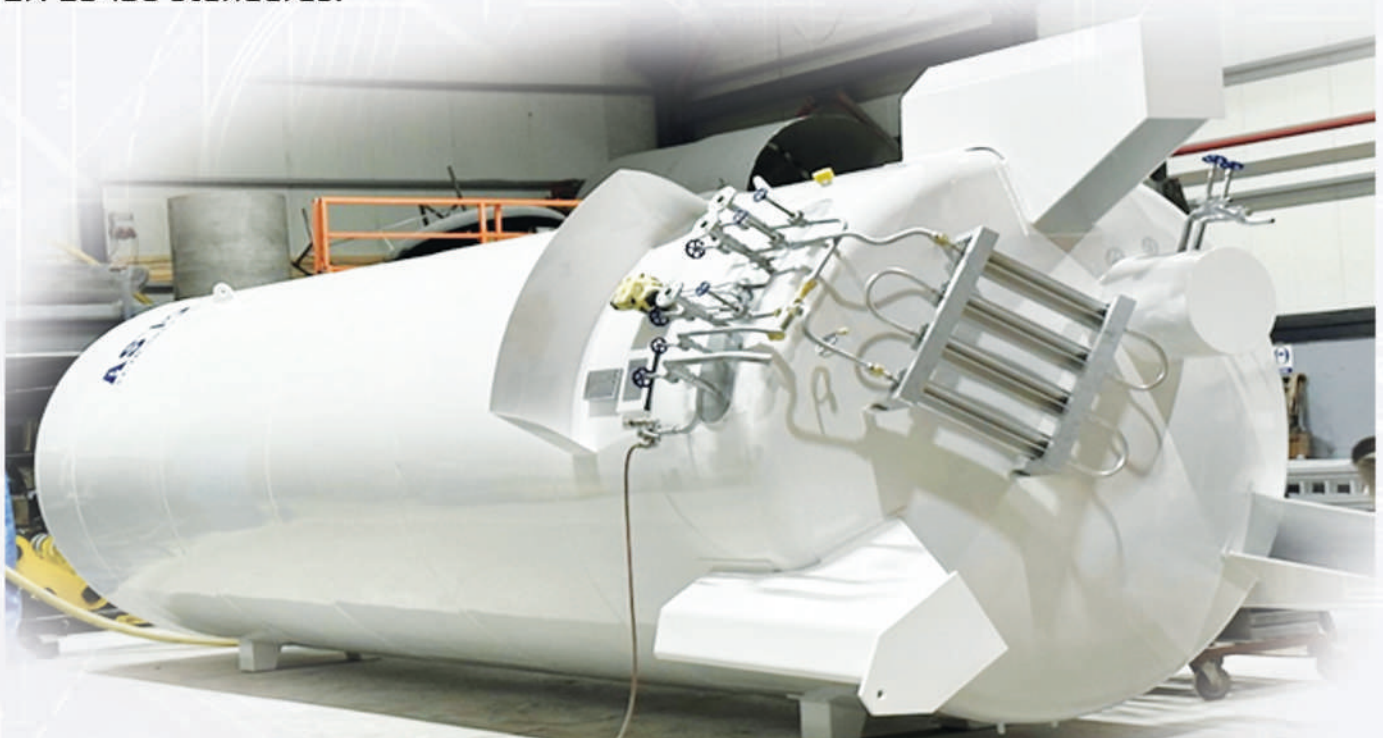

PUR INSULATED HIGH-CAPACITY CARBON DIOXIDE TANKS

High Capacity carbon dioxide storage tanks are designed for long term liquid carbon dioxide storage. PUR insulated carbon dioxide tanks are manufactured both horizontally and vertically depending on customer preference.

Tanks insulated with polyurethane are covered with aluminum jacket. In this way, the insulation is protected against mechanical damage and moisture as well as providing an aesthetic appearance. Carbon dioxide storage tanks can be designed according to our customer's requirements. The maximum working pressure of PUR insulated high-capacity carbon dioxide which is reduced from 60 tons to 300 tons, tanks is up to 24 bar.

These tanks, which are well insulated for ease of use, are equipped with safety valves, heaters, load-cell, weighing systems and cooling units that allow the carbon dioxide, which heats up over time and passes into the gas phase, to be cooled again.

There are double safety valves in the tanks against the risk of excessive increase in pressure. Carbon dioxide tanks are designed according to EC PED 97/23/EC directive using AD2000 and EN 13458 standards. ASME Section VIII Div 1 and other local pressure vessel standards can also be applied upon request.



LPG STORAGE TANKS

Standard LPG and Pressurized Tank Capacities:

- 5 m³ LPG Storage tank
- 10 m³ LPG Storage tank
- 15 m³ LPG Storage tank
- 20 m³ LPG Storage tank
- 30 m³ LPG Storage tank
- 40 m³ LPG Storage tank
- 50 m³ LPG Storage tank
- 115 m³ LPG Storage tank
- 180 m³ LPG Storage tank



LPG or other pressurized tanks can also be manufactured in intermediate capacities upon request.

AD MERKBLATT CDDE 2000, EN 13445, ADR 2013, EN 12493 and A5ME Section VIII Division 1 are used as design standards for tanks. Production can be made in different standards in line with customer requests. P class carbon steel materials are used in LPG tanks. The materials required by the product and pressure class to be stored in the tanks are used

LPG TRANSPORT TANKS

Production flexibility in different capacities in accordance with customer demand, Various installation variations in accordance with customer needs, Optional design conditions suitable for the region where the product will be used, Excellent ergonomic design in operation and service, Non-destructive testing tests in accordance with the standards (Radiographic test, Penetrating test, Ultrasonic test,)



DESIGN CONDITIONS

DESIGN CODE	: EN 12493/ADR
DESIGN PRESSURE	: 15 bar - 26 bar
DESIGN TEMPERATURE	: -50°C/+70°C
MATERIAL RT	: EN 12493
CONTROL	
LIQUID PENETRANT TEST	: EN 12493



AIR AND GAS TANKS



Zeeman air and gas tanks are designed using **AD2000** and **EN 13445** standards according to **EC PED 97/23/EC** directive.

ASME Section VIII Div 1 and other local pressure vessel standards can also be produced on demand.

We manufacture tanks for industrial gases, chemical and petrochemical industry, food and many other industrial sectors. Buffer tanks, air and gas tanks and pressure vessels are produced according to the needs of our customers.



As with all manufactured pressure vessels, air and gas tanks are subjected to all tests required by the manufacturing standard used and the entire process is carried out under the control of an impartial inspection organization.

PRESSURE CHAMBERS (HYPERBARIC CABINET APPLICATIONS)

During HBOT, the vast majority of patients normally breathe 10% oxygen under a pressure of 2-2.5 times the atmospheric PRESSURE we are in. Due to possible side effects of oxygen, air breaks are given at certain intervals. Masks or caps given to patients should be worn properly in order to obtain the desired level of oxygen.

It is possible to communicate continuously with patients during HBOT thanks to the communication equipment of the pressure chambers. In some pressure rooms, there are equipment where patients can listen to music and watch television.



A pressure chamber, also known as a hyperbaric chamber, is a system, mostly made of steel, that can be pressurized to a value higher than atmospheric pressure and is used for therapeutic and/or diving applications with integrated systems.

Due to the presence of people in it, pressure chambers are manufactured in the light of international standards (AD2000, ASME PVHD, etc.). There are seats for patients to sit comfortably in the pressure room. Patients on stretchers can also be treated lying down.



PROCESS TANKS AND REACTORS

In line with the requests of our customers, we manufacture in accordance with the process. All the products are manufactured in DIN, CE, TÜV, BREAU VERITAS, RINA, DNV GL, GOST quality standards and under the supervision of Chamber of Mechanical



The company, which manufactures for use in industrial production processes, also provides services in standard sizes and specifications. In many enterprises, these standardized productions are not sufficient and special production is required.

In this case, the company does not leave our valued customers alone and manufactures special tanks and equipment.



In special designs and productions, our technical team determines the size and shape of the tank according to the project design and offers flexible options for the thickness of the thermoplastic according to the needs. Special tanks can be different in everything from their intended use to the businesses they are used in.

For this reason, those in need should design the product they want correctly and have it produced by our technical team in a correct and high quality manner in accordance with the purpose.





EVAPORATORS



Atmospheric vaporizers are equipment that re-gasifies or vaporizes cryogenic liquids in the most cost-effective way. It uses heat from the atmosphere to vaporize the cryogenic liquid to meet the required energy needed.

Zeeman manufactures tank pressurizers, low- and high-pressure vaporizers in different capacities.

GENERAL SPECIFICATIONS

- Production in accordance with 97/23/EC (Pressure Equipment Regulation),
- Evaporator design suitable for use with high performance in heating surface area and evaporation capacity,
- All materials made of aluminum,
- Optional electric heater, high-pressure evaporator production according to customer requirements,
- Use of stainless steel rotating flange in liquid inlet and gas outlet
- Aluminum materials AW-6060 (EN 573-3) quality.

High pressure natural draft vaporizers are specifically designed for high pressure gas applications, including cylinder filling and laser applications. Products for the heating system are manufactured to standards that meet the requirements of the 150 9001:2008 quality system and CE.

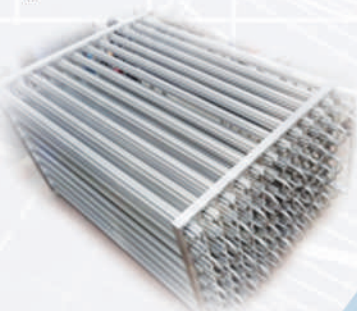



Inspecco CERTIFICATE
This is to certify that the Management System of
ZEEMAN PETROKİMYA MÜHENDİSLİK LTD. ŞTİ.
YAYLACK MAH. METİN SOK. NO:16/A BAŞIŞKELE / KOCAELİ

has been assessed and approved by INSPECCO Zertifizierungs- und Inspektordienstleistungen GmbH against the following standard:
ISO 9001:2015

The Quality Management System is applicable to
METAL TANK MANUFACTURING, MANUFACTURING OF CRYOGENIC TANKS, MANUFACTURING OF LIQUEFIED GAS (FLUID POWER) TANKS, EVAPORATOR MANUFACTURING, TANK METAL AND MACHINE SPARE PARTS MANUFACTURING, TANK PARTS DESIGN AND ENGINEERING ACTIVITIES, CRYOGENIC TANK MAINTENANCE AND ITS COMPONENTS SALES, INSTALLATION AND SERVICES (Excludes: ...)

Certificate No: INS 38-100-307
Certificate is valid from/til: 03.01.2024 / 02.01.2025
Certificate issue date/ location: 03.01.2024
Certificate first issue date: 03.01.2024
Certificate revision No: 01
EA Code: 17.18.20.34

General Manager: 

WE BUILD TRUST

ISO 9001:2015



Inspecco CERTIFICATE
This is to certify that the Management System of
ZEEMAN PETROKİMYA MÜHENDİSLİK LTD. ŞTİ.
YAYLACK MAH. METİN SOK. NO:16/A BAŞIŞKELE / KOCAELİ

has been assessed and approved by INSPECCO Zertifizierungs- und Inspektordienstleistungen GmbH against the following standard:
ISO 14001:2015

The Environmental Management System is applicable to
METAL TANK MANUFACTURING, MANUFACTURING OF CRYOGENIC TANKS, MANUFACTURING OF LIQUEFIED GAS (FLUID POWER) TANKS, EVAPORATOR MANUFACTURING, TANK METAL AND MACHINE SPARE PARTS MANUFACTURING, TANK PARTS DESIGN AND ENGINEERING ACTIVITIES, CRYOGENIC TANK MAINTENANCE AND ITS COMPONENTS SALES, INSTALLATION AND SERVICES (Excludes: ...)

Certificate No: INS 38-405-134
Certificate is valid from/til: 03.01.2024 / 02.01.2025
Certificate issue date/ location: 03.01.2024
Certificate first issue date: 03.01.2024
Certificate revision No: 01
EA Code: 17.18.20.34

General Manager: 

WE BUILD TRUST

ISO 14001:2015



Inspecco CERTIFICATE
This is to certify that the Management System of
ZEEMAN PETROKİMYA MÜHENDİSLİK LTD. ŞTİ.
YAYLACK MAH. METİN SOK. NO:16/A BAŞIŞKELE / KOCAELİ

has been assessed and approved by INSPECCO Zertifizierungs- und Inspektordienstleistungen GmbH against the following standard:
ISO 45001:2018

The Occupational Health and Safety Management System is applicable to:
METAL TANK MANUFACTURING, MANUFACTURING OF CRYOGENIC TANKS, MANUFACTURING OF LIQUEFIED GAS (FLUID POWER) TANKS, EVAPORATOR MANUFACTURING, TANK METAL AND MACHINE SPARE PARTS MANUFACTURING, TANK PARTS DESIGN AND ENGINEERING ACTIVITIES, CRYOGENIC TANK MAINTENANCE AND ITS COMPONENTS SALES, INSTALLATION AND SERVICES (Excludes: ...)

Certificate No: INS 38-1000-038
Certificate is valid from/til: 03.01.2024 / 02.01.2025
Certificate issue date/ location: 03.01.2024
Certificate first issue date: 03.01.2024
Certificate revision No: 01
EA Code: 17.18.20.34

General Manager: 

WE BUILD TRUST

ISO 45001:2018



Inspecco SERTİFİKA
ZEEMAN PETROKİMYA MÜHENDİSLİK LTD ŞTİ.
YAYLACK MAH. METİN SK. NO:16A BAŞIŞKELE - TEPEKİ - KOCAELİ

Firmamız
ISO 10002:2018

Standartına göre Müşteri Memnuniyeti Yönetim Sistemini uygularız

BASINÇLI KAPLAR, KRİYOJENİK TANKLAR (LIN-LAR-LOX), KARBONDİOKSİT TANKLARI, LNG TANK VE SİSTEMLERİ, EVAPARATÖRLER, MEDİKAL GAZ SİSTEMLERİ, HİPERBARİK KABIN, TAŞIYICI, MALAT, KURULUMU VE SERVİS HİZMETLERİ (Herç Türünde ...)

kapsamında, INSPECCO Zertifizierungs- und Inspektordienstleistungen GmbH tarafından değerlendirilmiştir.

Sertifika No: INS 38-200-149
Sertifika Geçerlilik süresi: 01.08.2023 / 31.05.2024
Sertifika Yayın Tarihi ve yeri: 01.08.2023 - TEPEKESKİT
Sertifika ile Yayın Tarihi: 03.08.2023
Sertifika Revizyon No: 01
EA Kodu: 17

Genel Müdür: 

WE BUILD TRUST

ISO 10002:2018



Inspecco SERTİFİKA CERTIFICATE
ZEEMAN PETROKİMYA VE MÜHENDİSLİK LTD. ŞTİ.
Karadenizler Mah. Bayatlı Cd. No: 158
Başışkele - Kocaeli / TÜRKİYE

yağlıca dairesel kesitli borular için uygundur

başarılı olarak ve birleştirilmiş baskı tesisatı kapsamında
the scope of manufacturing pressure equipment and cryogenic tank according to

TS EN ISO 3834-2: 2021

Materyal malzemesinin uygunluğu için baskı testleri - Bölüm 2: Başarılı baskı testleri
Quality requirements for fusion welding of metallic materials - Part 2: Comprehensive quality requirements
gerekliklerini karşıladı. glikülasyon. Sertifika kapsamı ile ilgili detaylı bilgi ekte belirtilmiştir
and found to meet the requirements. Details of the certificate scope have been stated in the appendices.

Sertifika yalnızca uygun kesitli borular, standart ve sertifikasyon kurulumu şartlarında geçerlidir.
The certificate is valid for circumstances that are stated above, as long as the rules of the standard and certificate followed.

Sertifika No: 22952901 | Dairesel Boru No: 22952901.3
Certificate No: | | Audit Report No: |

Yer - Değerlendirme Tarihi: İstanbul - 12.09.2022 | Sertifika Geçerlilik Tarihi: 11.09.2025
Place Date of Issue: | Valid Until:

Genel Müdür: 

WE BUILD TRUST

TS EN ISO 3834-2:2021 / A



Inspecco

Sertifika No: 22952901
Certificate No:

Sayıca Yöntemli İşleyiş Prosedürü (SPP/SPH)	Ana Malzeme Grubu (EN ISO 5818)	Birleştirme Tipi Joint Type	Kalınlık Ölçme Aralığı (Agreement Range of Thickness) (mm)
141	8.1	BW, FW	3-20
141	8.1	BW, FW	BW: 1.385-5.54; FW: 1.930-5.54 Ø ≥ 24.15
141	1.2	BW, FW	3-24
111	1.2	BW, FW	3-24
135	1.2	BW, FW	3-24

Destekleyici Standartlar
Supporting Standards: TS EN ISO 15614-1, TS EN ISO 15608-1, TS EN ISO 16969-1, TS EN ISO 14731

Adı - Soyadı Name-Surname	Yetkisi Qualification	Teknik Bilgi Seviyesi Technical Knowledge
Alan DEMİR	İWE (TR)/IWE(23-05042019-13)	Kapsamlı Comprehensive

Genel Müdür: 

WE BUILD TRUST

TS EN ISO 3834-2:2021 / B



BRAND Regr. Certificate



MODUL B



TS EN ISO 14732: 2014



ISO 13485:2016

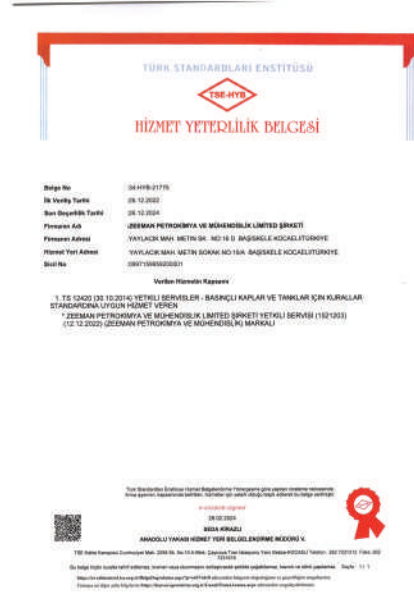

TSE Service Qualif. Certificate



MODUL F

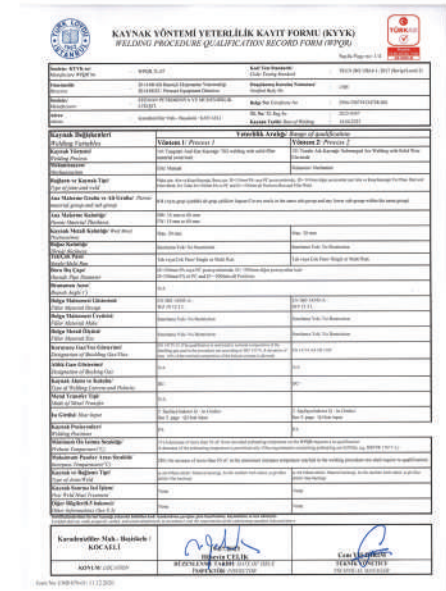

WELDING MANAGEMENT

OUR CERTIFICATES



ZEEMAN
ENGINEERING

Yaylacık Mah. Metin Sok. No.16A
Başiskele / KOCAELİ

(+90) 506 850 41 65

info@zeemanmuhendislik.com



zeemanmuhendislik.com

ZEEMAN
PETROKİMYA VE MÜHENDİSLİK